

## 8 各部零件說明 Description

ICS-170

\*每一款槍型基本配備不同依實際出貨為主。圖片僅供參考。  
The components/accessories for each model may have kind of differences depending on the actual goods. Images are only for reference.

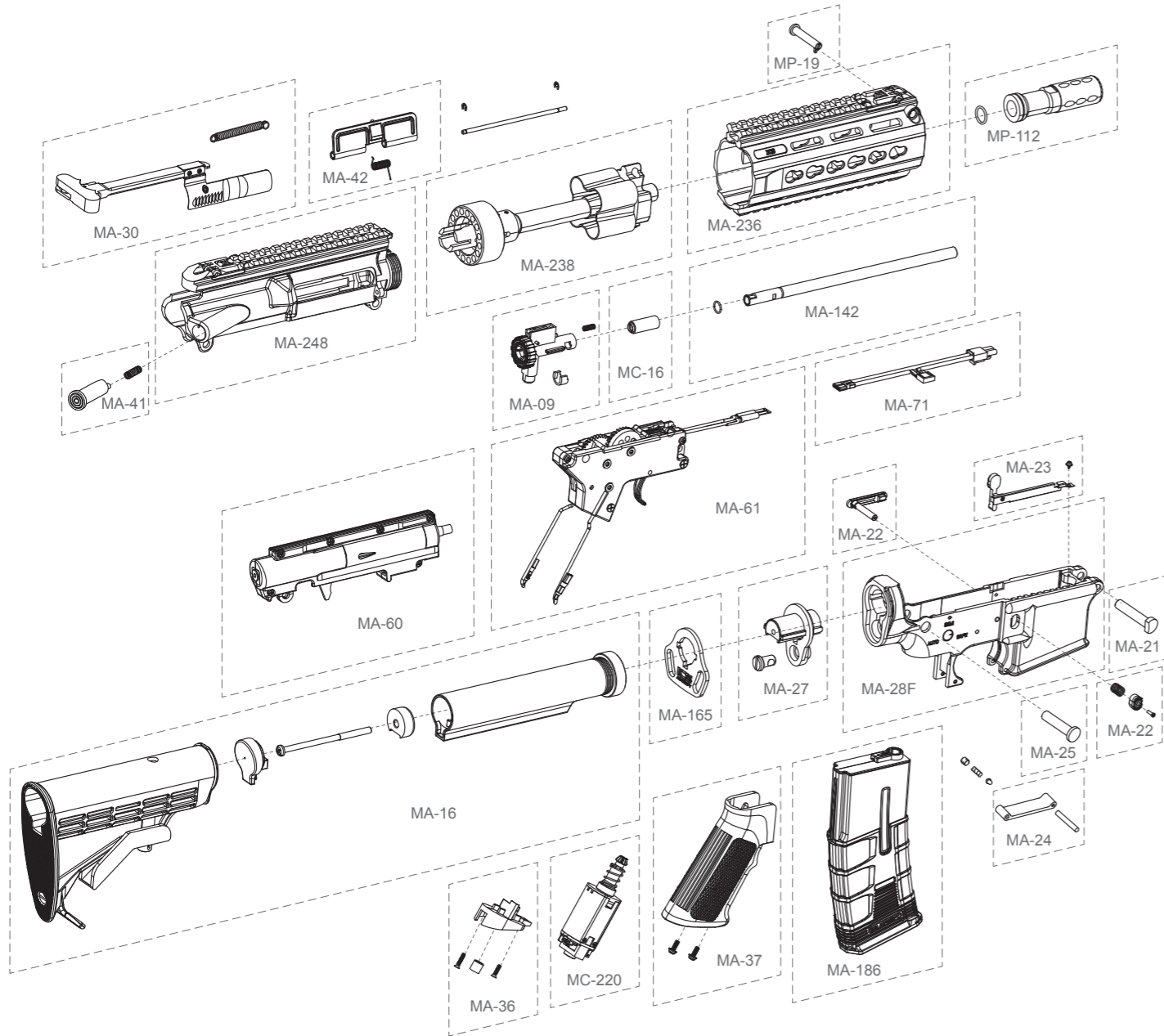

Patents acquired: R.O.C. M244431 / US7077117B1 / R.O.C. D159178 / USD706880S / R.O.C. M320468 / R.O.C. M351340 / EM002246579-0001

## WARNING 警告 電槍使用之注意事項 Maintenance

- 請勿使用劣質或回收BB彈，以減少槍管損耗及避免卡彈。
- 一旦發生卡彈或射擊速度降低時，應立即停止射擊，以避免齒輪過度耗損。請使用通槍條將殘彈清除，或被測電池電量後方可繼續使用。
- 不使用本產品時，請務必將射擊選擇鈕置於保險(S)的位置上，將電池移除並定期使用通槍條清潔槍管。
- 請依原廠附贈之保險絲規格使用。不當配置可能導致零件故障，槍內配置M100彈簧請用20A保險絲，M120彈簧請用25A保險絲。
- 彈頭直徑6mm。其槍口動能為二焦耳以下、射程範圍為50公尺以內。
- 適用年齡為18歲以上。
- 使用本商品不得改造或變造，並不得使用金屬彈頭。
- 「此槍非玩具」，濫用可能導致嚴重傷害，尤其是眼睛。使用時應確保本身及射擊範圍內所有人員均已確實穿戴護目鏡。
- 使用方法及注意事項請詳閱說明書內容。
- 建議使用以下電池以達到最大效益：  
SSS系統建議使用7.4v & 11.1v Li-Po電池。  
傳統電筒與FET電筒系統11.1v Li-Po電池Ready。  
※使用非建議電池可能會造成產品效能低落、功能異常甚至損毀。  
(原產地：台灣 / 製造商：一芝軒企業有限公司 / 地址：台中市神岡區東洲路79巷67號 / 電話：04-25256461)
- To reduce the abrasion of inner barrel and to avoid BB jam, please do not use inferior or reused BB pellets.
- If your gun is jammed or the muzzle velocity has decreased, please stop shooting immediately in case the gear abrades excessively. Use the clearing rod to clear out the remaining pellets, or check your battery power before continue using your gun.
- Please engage the safety, dismount the battery and clear the inner barrel with the clearing rod periodically when not using this product.
- Please use the same fuse specification as the original one. Equipping improper fuse might cause malfunction to the components. Apply 20A fuse if the gun using a M100 spring; apply 25A fuse if using M120 spring.
- The diameter of the BB pellet is 6mm. The muzzle energy is less than two joules, and the shooting range is within 50 meters.
- The recommended age to operate this product is 18 years old and above.
- Modify, reform, and using metal bullets on this product are strictly forbidden.
- This is NOT a toy. Abusing might cause severe injuries, especially to the eyes. Before operating, please make sure that every personnel in the shooting range have worn eye protections properly, including the operator.
- Please read the manual for instruction and precaution.
- In order to achieve the maximum performance, the following batteries are recommended:  
SSS system: 7.4v or 11.1v Li-Po batteries.  
Traditional switch and FET switch system: 11.1v Li-Po battery Ready.  
※Using non-recommended batteries may cause poor performance, abnormal functions or even damage to the product.  
Origin: Taiwan / Manufacturer: ICS enterprise Co., Ltd / Address: No.67, Ln. 79, Dongzhou Rd., Shengang Dist., Taichung City 429, Taiwan / TEL: (+886) 4-2525-6461



BE A GAME CHANGER ICS AIRSOFT

## 1 各部名稱 Series Component

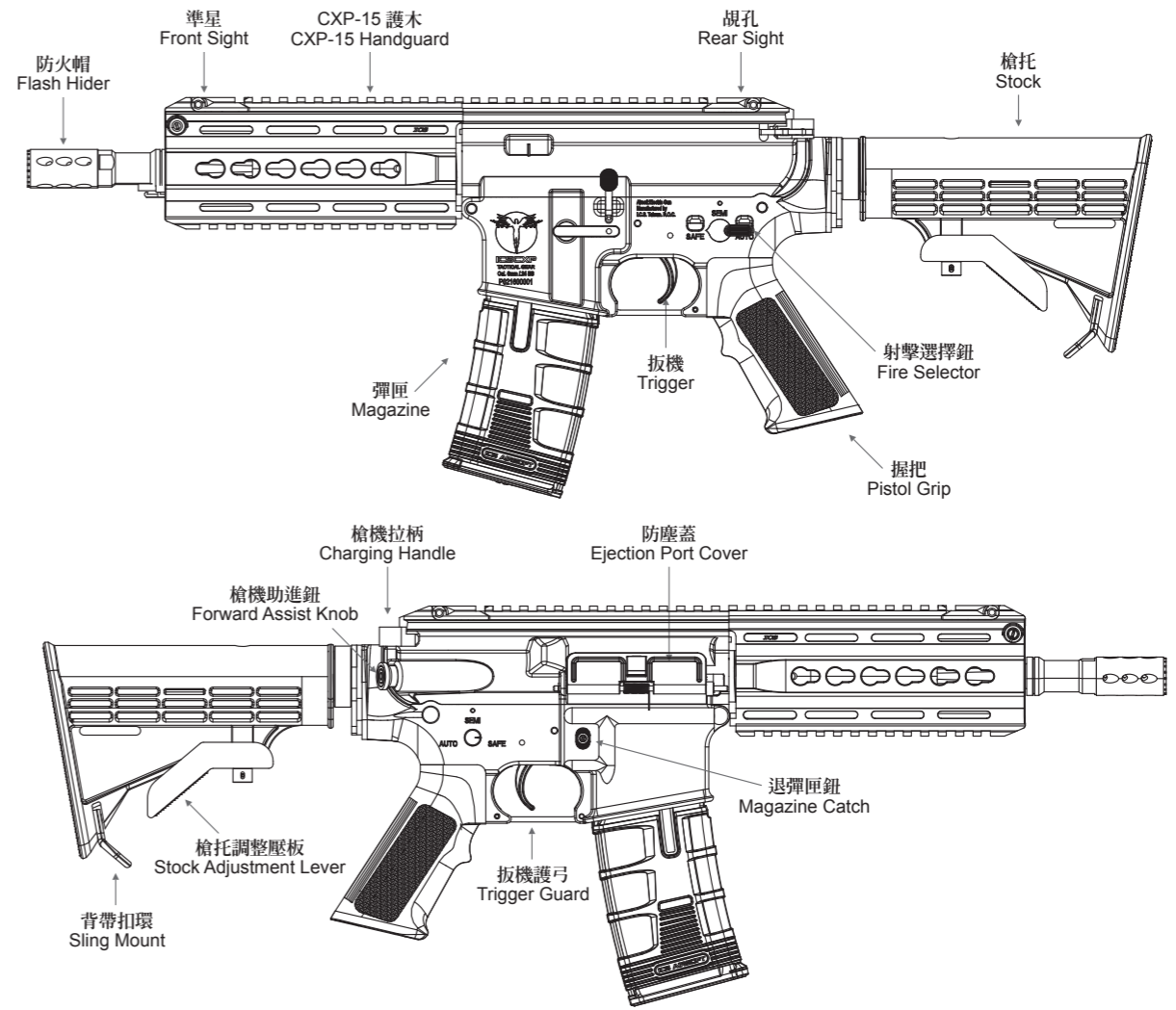

相關系列產品型號與詳細規格，請以官方網站公布為主。  
For related series product models and detailed specifications, please refer to the official website.

## 2 彈匣使用方式 Magazine Attachment

### 2-1 裝BB彈方式 Load BBs

將彈匣上蓋依箭頭方向打開再倒入BB彈。  
Open the cover to load BBs.

建議使用 6mm BB彈。  
6mm caliber BBs are recommended for optimum performance.

依箭頭方向旋緊彈匣底旋鈕，即可將BB彈順利送出。  
To charge BB feed spring, please rotate the gear under the magazine.

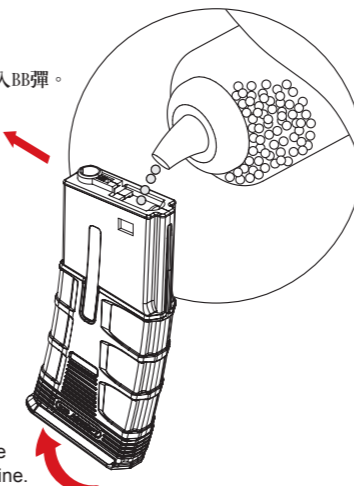

### 2-2 裝卸彈匣 Magazine Loading and Unloading

- 直接將彈匣插入彈匣插槽。
- 按壓退彈匣鈕即可將彈匣卸下。

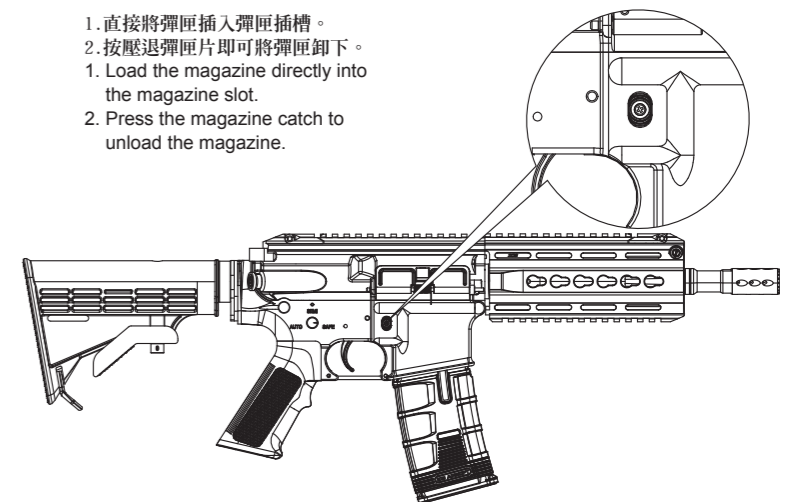



### 3 可動部的說明 Movable Parts

#### 3-1 可作動作 Movable Parts

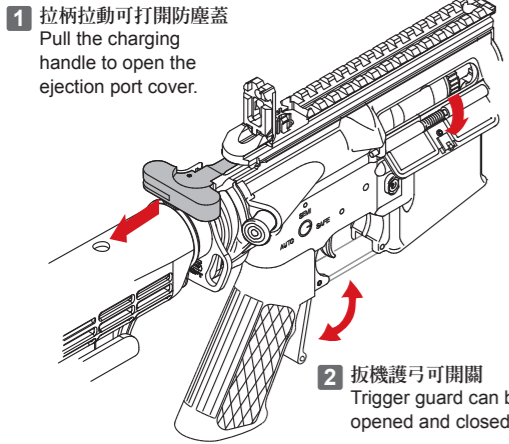

※此系列產品具備「彈簧釋放功能」。

- 槍枝上彈的情況下，按壓槍機助進器可釋放彈簧，再次擊發時有機率造成第一發雙彈射出或者小便彈，屬正常情況。
- 槍支使用完畢後：
  - 請轉至單發模式下，擊發2~3下後做清槍動作
  - 關保險並確保槍管內已無殘彈
  - 按壓槍機助進器釋放彈簧
- 上下槍身分解前，務必先關保險並釋放彈簧，避免造成齒輪倒轉損壞活塞。

※釋放彈簧可延長彈簧壽命，避免長期擠壓造成疲乏。

※This series has "spring release" function.

- If the AEG is loaded with magazine, the spring can be released by pressing the forward assist knob, but also has chance to fire 2 BBs on your first shot or fire with low muzzle velocity, which are normal conditions.
- Once you finished using your AEG:
  - Please select your fire selector to semi-auto, clear your gun by firing 2 to 3 times.
  - Engage the safety and make sure no BB pellets are remained in the barrel.
  - Press the forward assist knob to release the spring.
- Before you disassemble the upper and lower receiver, make sure you have engaged the safety and released the spring, to avoid gear reversal and cause damage to the piston.

※Releasing the spring can extend its service life time, and avoid elastic fatigue caused by long-term extrusion.

#### 3-2 槍身結合3號齒輪箱正確位置圖 The correct position of sector gear before reassembling

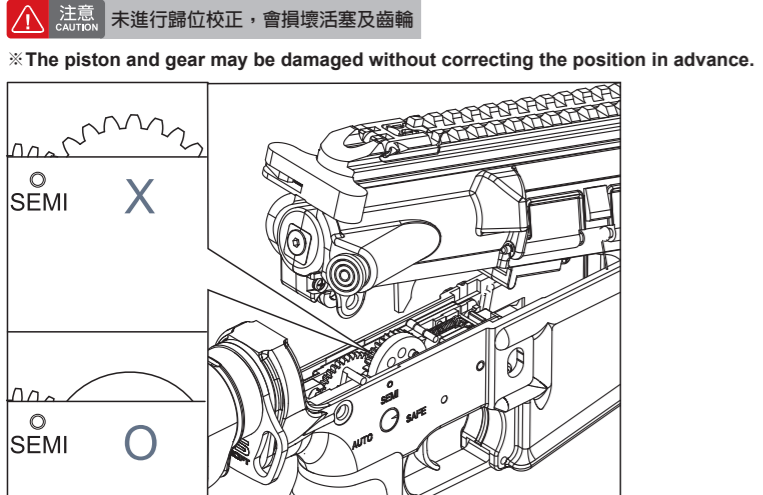

3號齒在槍身結合時，必須轉到正確位置，才可將上槍身蓋下。  
Make sure the sector gear is turned to the correct position before reassembling the receiver / gearbox.

#### 3-3 調整伸縮托長度 Adjust Retractable Stock Length

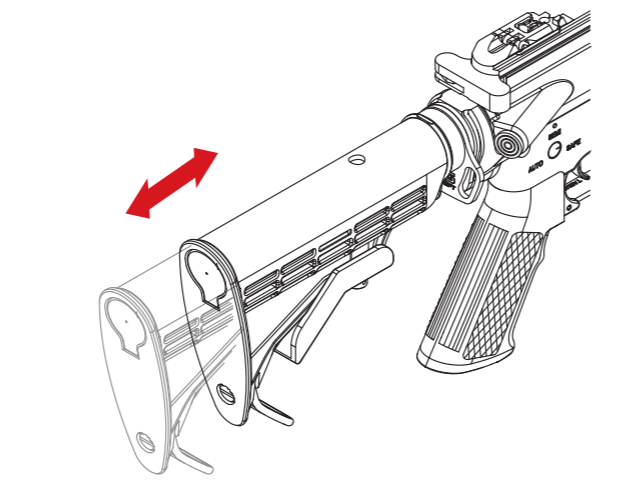

按壓槍托調整桿，即可將伸縮托向後拉或向前托，共有6段可供調整長度。  
Press and hold the stock adjustment lever to adjust stock length forward and backward. A total of 6 lengths are available for adjustment.

### 4 精確射擊調整動作 Precision Targeting Adjustment

#### 4-1 準星視孔調整方式 Front and Rear Sight Adjustment

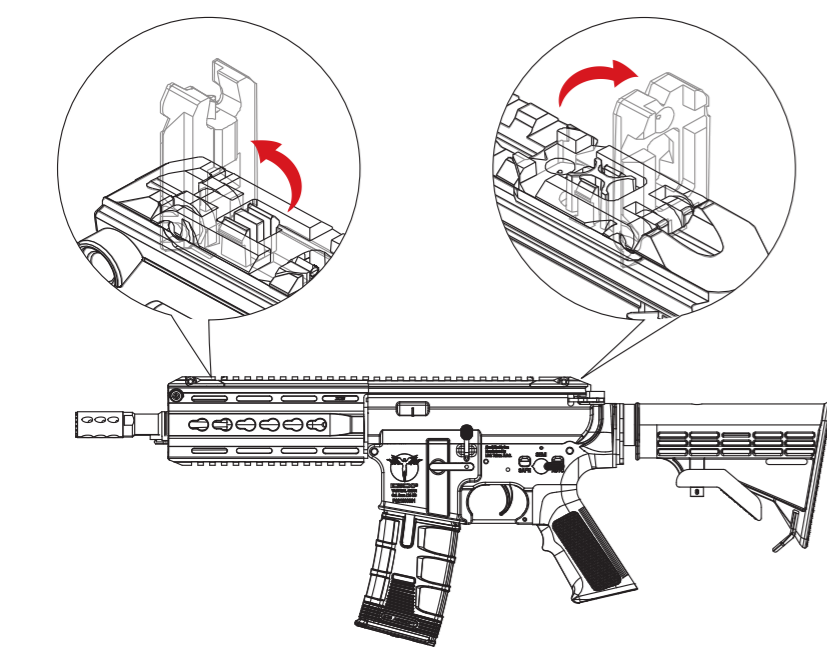

#### 4-2 選擇射擊模式 Shooting Mode Setting

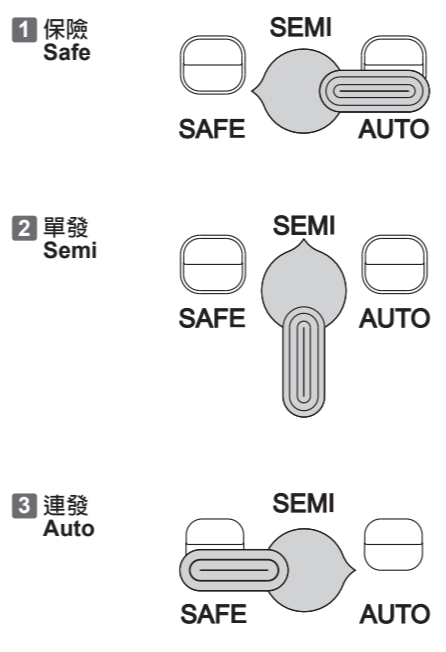

### 5 H-UP 彈道調整 H-UP Adjustment

注意 CAUTION 非必要時，手指請勿放置於H-UP調整處，避免受傷

※To avoid injuries, only put your finger on the H-up adjustment when necessary.

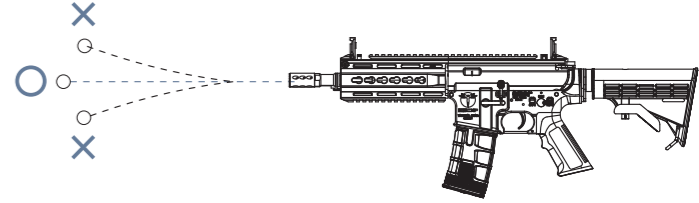
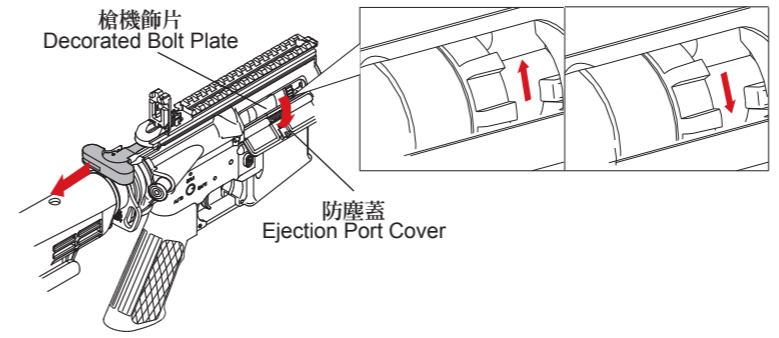

- 將槍機拉柄往後拉(不可放開)，防塵蓋下翻、槍機飾片向後打開，即可進行彈道調整。
- 視彈道進行撥盤調整，調整完即可放開槍機拉柄。

- To adjust the trajectory, pull and hold the charging handle to the end (do not release) to open the ejection port cover downward, and open the decorated bolt plate backward.
- Rotate the dial to adjust the trajectory. Release the charging handle once you finished the adjustment.

H-UP調整：BB彈呈現一直線的彈道才是正確射法。  
過於上飄：將撥盤往前推。  
過於下墜：將撥盤往後拉。  
H-up Adjustment: Make sure the trajectory of the BB pellets to be straight.  
When the BB pellet flies up: Push the H-UP lever forward to lower the trajectory.  
When the BB pellet falls down: Push the H-UP lever backward to raise the trajectory.

### 6 電池的拆裝方法 Battery Installation and Disassembly

注意 CAUTION 重新組裝時，必須依反向動作做組合

※Reassembling is the reverse of disassembling procedures.

#### 6-1 前出線版本 Front Wired

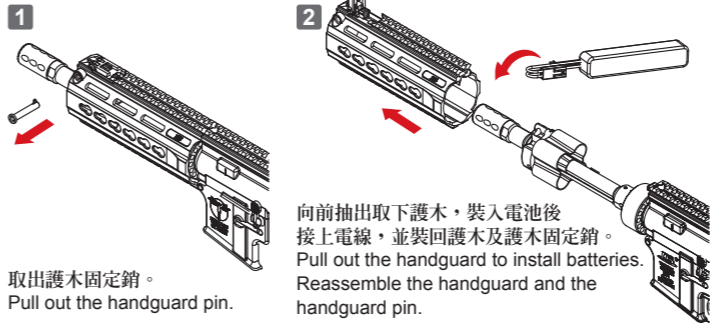

取出護木固定銷。  
Pull out the handguard pin.

向前抽出取下護木，裝入電池後接上電線，並裝回護木及護木固定銷。  
Reassemble the handguard and the handguard pin.

#### 6-2 後出線版本 Rear Wired

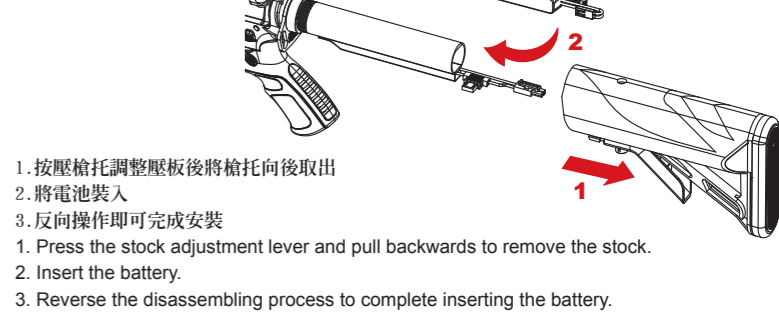

- 按壓槍托調整壓板後將槍托向後取出
- 將電池裝入
- 反向操作即可完成安裝

- Press the stock adjustment lever and pull backwards to remove the stock.
- Insert the battery.
- Reverse the disassembling process to complete inserting the battery.

### 7 齒輪箱拆解 Disassemble Gearbox

注意 CAUTION 先卸彈匣跟電池，再進行拆解

※Unload the magazine and battery before you proceed to disassemble.

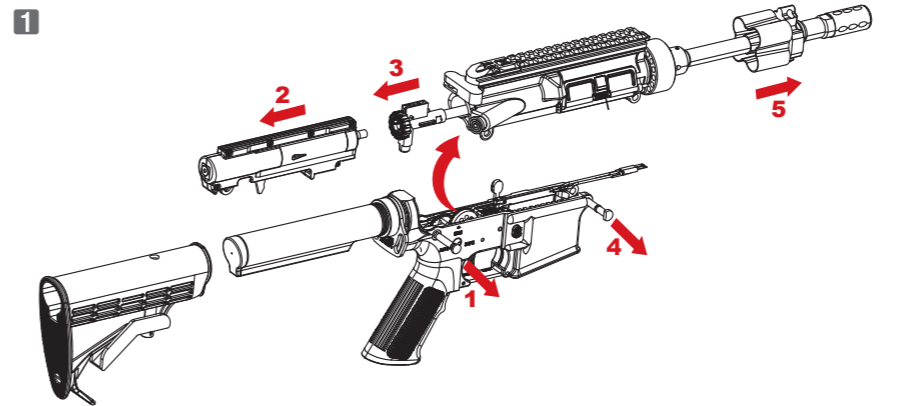

- 先將後槍身結合銷推出即可打開上槍身
- 將上齒輪箱取出
- 取出H-UP組
- 再將前槍身結合銷推出
- 取出上槍身

- Push out the rear receiver pin to open the upper receiver.
- Take out the upper gearbox.
- Take out the H-UP set.
- Push out the front receiver pin.
- Separate the upper receiver

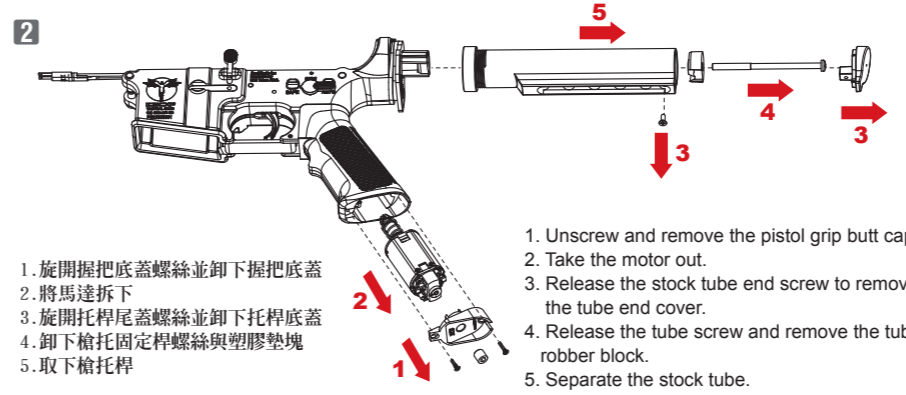

- 旋開握把底蓋螺絲並卸下握把底蓋
- 將馬達拆下
- 旋開托桿尾蓋螺絲並卸下托桿底蓋
- 卸下槍托固定桿螺絲與塑膠墊塊
- 取下槍托桿

- Unscrew and remove the pistol grip butt cap.
- Take the motor out.
- Release the stock tube end screw to remove the tube end cover.
- Release the tube screw and remove the tube robber block.
- Separate the stock tube.

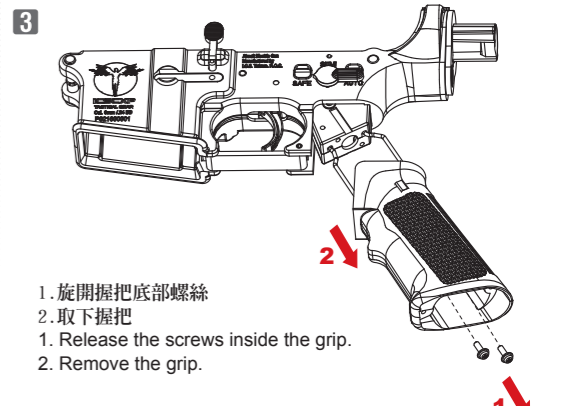

- 旋開握把底部螺絲
- 取下握把

- Release the screws inside the grip.
- Remove the grip.

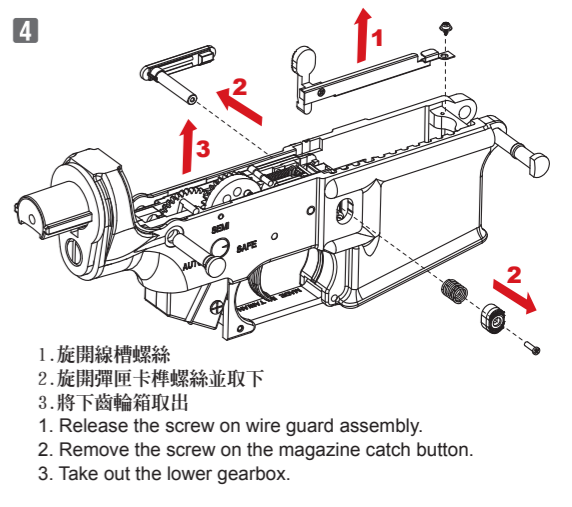

- 旋開線槽螺絲
- 旋開彈匣卡榫螺絲並取下
- 將下齒輪箱取出

- Release the screw on wire guard assembly.
- Remove the screw on the magazine catch button.
- Take out the lower gearbox.