

**WARNING**

- To avoid damaging the product, please release the gas from the magazines or cartridges while not operating.
- Sales and usage are restricted to 18-year-old people or older. Those below 18 years old are not allowed neither to purchase nor to operate alone.
- Never aim or shoot at people or animals. Please beware of childrens' mis-handling.
- Please read and fully understand all details listed in this instruction manual before using this air gun. You can download it from [www.icsbb.com](http://www.icsbb.com) if you lose this instruction manual.

6mm BB



## 1 PART DESCRIPTION

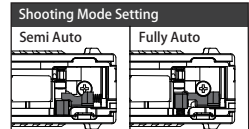
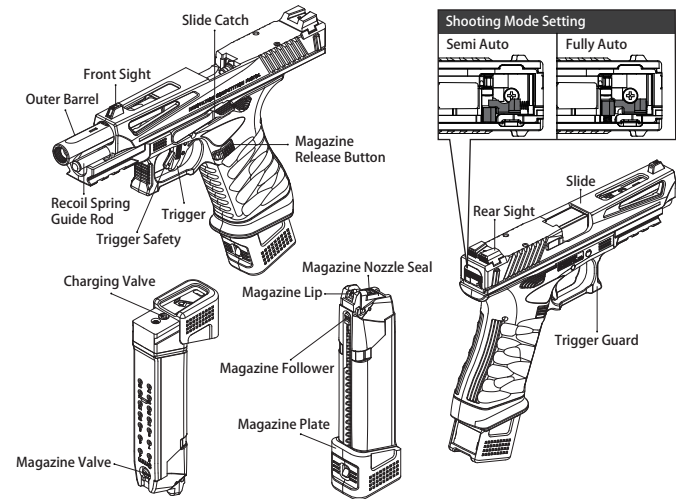

**WARNING-ATTENTION**

This model is featured with Gas-Blow-Back function, the slide will be pushed back and forth by the gas pressure strongly and rapidly while firing. To prevent injury, please keep your face and finger away from the slide.

The pistol could be damaged when using at temperature of 35°C (95°F) or above.

## 2 SAFETY DEVICE

- If the Trigger Safety is not pressed properly, it will not fire normally.
- The Trigger Safety needs to be pressed properly to fire normally.

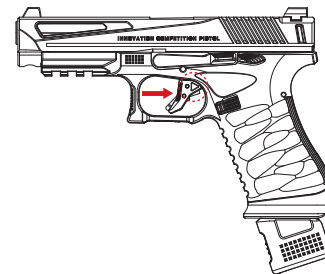

## 3 RMR RED DOT INSTALL

Before mounting on the slide, check the dimensions of the screws.  
Do not over tighten the screw, otherwise the cylinder will be stuck during the slide movement.  
Apply thread locker to make sure the stability.

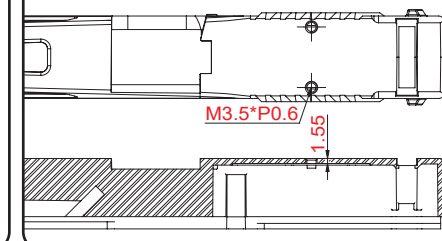

## 4 LOADING MAGAZINE



Load the magazine until it clicks into the locking position.  
Do not insert the magazine by force.

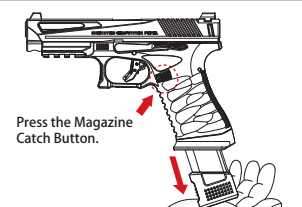

Release the magazine by pressing the Magazine Catch Button.  
Hold the magazine when releasing it from the pistol grip to prevent it from dropping.

**WARNING-ATTENTION**

- To prevent misfiring, keep your finger off the trigger and out of the trigger guard while loading the magazine.
- For safety reason, please remove the magazine while not operating.

## 5 CHARGING GAS

For the optimum product performance, please charge your magazine with 10-12kg airsoft use green gas. If you use green gas with non-recommended number of kg, it may cause damage or malfunction to the product.

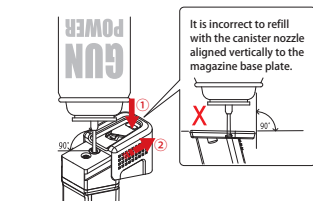

Please turn the magazine up side down to keep the injection hole side up, fill the gas only when the canister is verticalized to the injection hole.  
The gas will not be filled into the magazine or will leak out if the canister is not verticalized to the injection hole.

**WARNING-ATTENTION**

- Please avoid to touch the injection hole. It might cause frostbites or low temperature burns if the skin is adhered by the gas.
- To preserve the magazine, Dropping them may cause damage or abnormality.
- Please avoid foreign matter remains on the Magazine Lip and injection hole on the magazine, which may cause abnormality.
- If refilling is necessary, please avoid to proceed when the magazine is loaded. Please unload the magazine before proceeding.
- Please do not place the magazines in wet or watery places, which may cause abnormality.

## 6 LOADING BBs

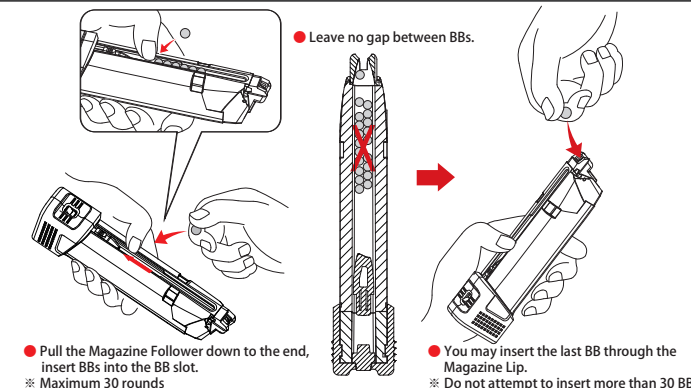

**WARNING-ATTENTION**

- Do not release the Magazine Follower abruptly while pressing the follower. Releasing the follower carelessly may damage the Magazine Lip.

## 9 SHOOTING

- Load the pistol according to Step 6.
- Pull the trigger to fire (a BB pellet will be fired and the slide will be pushed backward).

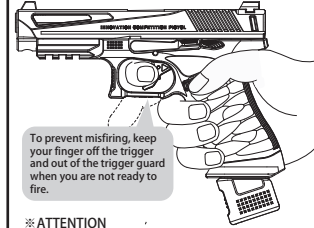

To prevent misfiring, keep your finger off the trigger and out of the trigger guard when you are not ready to fire.

- When the BB is loaded into the barrel, the following process will be proceeded and repeat automatically every time you pull the trigger: BB fired - Slide movement (blowed backward) - Load the next BB (Slide re-positioned) - Repeat automatically when long-pull the trigger.

**WARNING-ATTENTION**

- Power Depression: When the temperature inside the magazine is too low, the gas power will be depressed. The movement of the slide will be delayed. The slide Catch will not be bounced. The shooting range will not be far.
- Shooting posture: Please do not operate the pistol up side down for optimum performance.

## 10 STORAGE

- Press the magazine catch button to release the magazine.
- Make sure the inner barrel is clear. If not, pull the slide backward, and turn the pistol up side down to remove the remaining BB, make sure no BBs are left inside the barrel (Push the BB pellet out from the barrel by the clearing rod is recommended).
- Press the slide catch lever to release the slide.
- Pull the trigger and fire several times towards safety directions, and make sure no BBs are left inside the barrel.

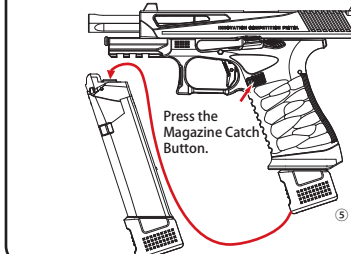

Warning - Attention!  
Low temperature gas will be vented out while releasing the gas. Never point the Magazine Nozzle Seal towards any object that you do not want to damage while operate to avoid frostbite.  
Release the remaining gas by pressing the Magazine Valve with either finger or Tool, to avoid elastic fatigue of your O-ring.

## 11 DISASSEMBLY (Do it when necessary)

Only disassemble your airsoft replica when adjusting the H-UP and proceeding to maintenance.

- Press the Magazine Release Button to unload.
- Pull the slide backward until the slide stop is aligned to the 1st notch from the left as shown.
- Press the slide stop button on the right to remove the slide stop.

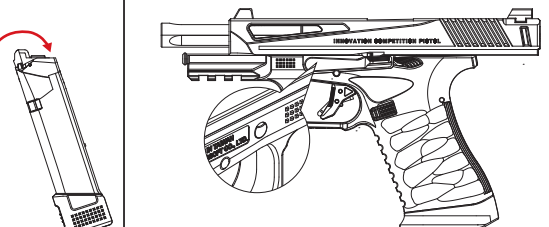

## 7 SHOOTING MODE SETTING

- Load the magazine for security reasons.
- Pull back the slide and press the slide catch upward to lock it.
- Turn the pistol up side down and push the fire selector lever to switch Semi / Fully auto mode.

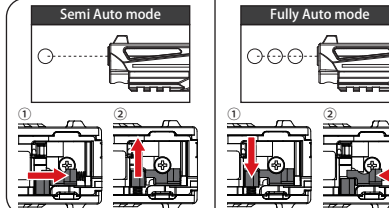

## 8 LOADING

- Insert the magazine.
- Pull the slide to the end and hold (the hammer will be down pressed).
- Release the slide (the slide is held at the back at the moment).
- Press the slide catch downward, the slide will be pushed forward (a BB pellet will be loaded into the barrel).



**WARNING-ATTENTION**

- Keep your face and fingers away from the slide while the slide is operating.
- When the pistol is unloaded, the slide can be pushed forward when you pull and release it from the end.
- When the pistol is loaded, loading repeatedly will makes the BBs load into the barrel repeatedly, which will lead to malfunction while firing and cause danger.
- When the hammer is pressed down, pulling the trigger will fire the BB. Please take extra notice.

## 11 DISASSEMBLY (Do it when necessary)

④ Push the slide forward to remove.

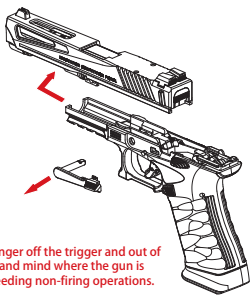

⑤ Push the Recoil Spring Guide forward and rise it to detach.  
⑥ Push the Outer Barrel Assembly slightly forward, and rise it to remove.

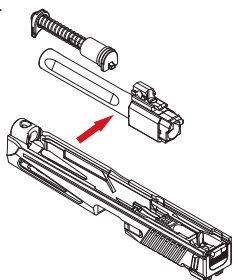

**ATTENTION**  
△ Please keep your finger off the trigger and out of the Trigger Guard, and mind where the gun is aiming while proceeding non-firing operations.

## 12 H-UP ADJUSTMENT

① Please disassemble and remove the slide as step 9 instructed.  
② Adjust the H-up dial with a screwdriver to adjust the height of the H-up.

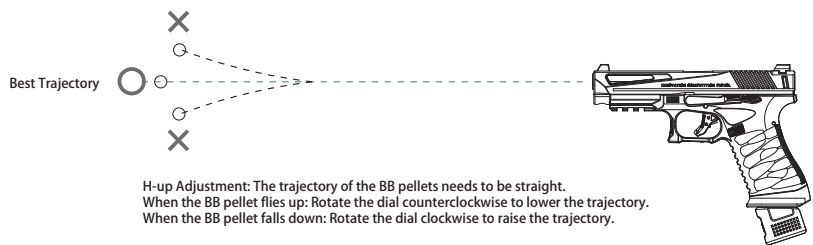
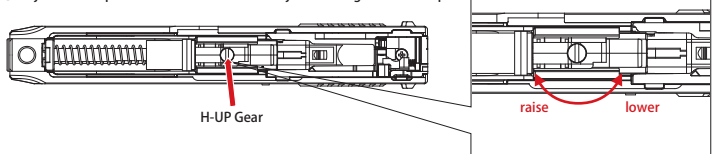

## 13 ASSEMBLY

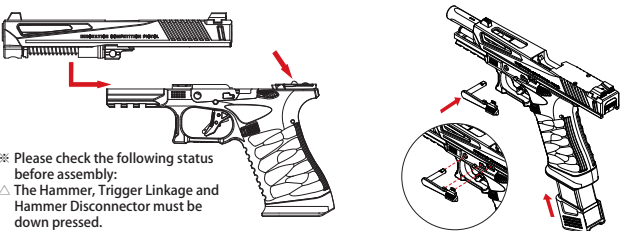

### WARNING-ATTENTION

● ICS will not be responsible for any part assembling errors, missing parts, and problems such as malfunctions, accidents, injuries, caused by malfunction, and all the maintaining expenses will be beared by the customer themselves.

※ Please check the following status before assembly:  
△ The Hammer, Trigger Linkage and Hammer Disconnecter must be down pressed.

① Insert the slide back to the receiver through the rail from the front.  
② Pull the slide backward until the slide stop is aligned to the 1st notch from the left as shown.

## 14 REVERSIBLE MAGAZINE CATCH

The magazine catch can be reversed by proceeding as follows (Note: The pistol must be field stripped pursuant to the instructions in Step 9 before the magazine catch can be reversed).

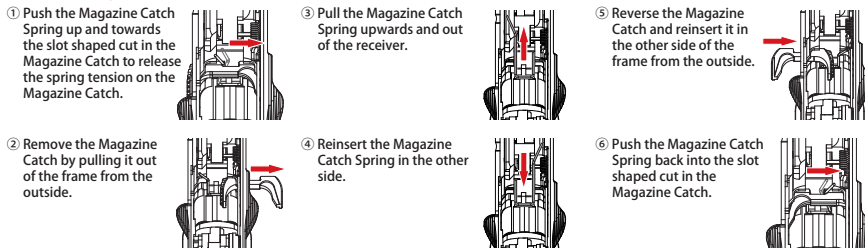

Insert an empty magazine into the frame and press the magazine release to confirm that it operates correctly. Repeat several times. Reassemble the pistol according to the instructions in Step 11.

## 15 BASIC TROUBLESHOOTING GUIDE

SYMPTOMS	POSSIBLE CAUSES	SOLUTIONS
No Response	Trigger has not been pulled firmly.	Pull the Trigger firmly.
	Magazine overpressured.	Press the valve gently to release gas and to adjust pressure. Be careful when gas is discharged from the Nozzle Seal.
	Insufficient gas inside the magazine.	Charge gas into magazine (refer to Step 4).
the slide blows back but no BB is fired	BB can't be loaded into the barrel.	Load the first BB into the barrel (refer to Step 6).
	BB is jammed inside the magazine.	Push out the BB by using the clearing rod, or pulling the slide backward, and turn the pistol up side down to remove.
Will not complete cycle	Magazine is too cold.	Use the magazine after it is returned to normal temperature (refer to Step 4).
	Temperature is too low.	
	Magazine is too cold.	
Slide jammed	No gas in the magazine.	Charge gas into magazine (refer to Step 4).
	Lubricant or silicon oil is not enough.	Apply lubricant to the moving parts.
	BBs or foreign matters jammed inside the slide or frame.	Remove the BBs or foreign matters.
Gas comes out from the barrel	Slide Catch is not switched back to locking position.	Press the slide Catch downward to release the slide.
	Temperature is too low.	Use the magazine after it is returned to normal temperature (refer to Step 4).
Magazine is too cold.		
BBs fly up	H-UP is over adjusted.	Rotate the dial counterclockwise to lower the trajectory (refer to Step 10).
Shooting range is too short	H-UP isn't adjusted enough.	Rotate the dial clockwise to raise the trajectory (refer to Step 10).
	Foreign matters or oil in the inner barrel.	Clean the inner barrel and H-UP bucking.
BBs roll out of barrel	H-UP isn't adjusted enough.	Rotate the dial clockwise to raise the trajectory (refer to Step 10).
	H-UP is over adjusted.	Rotate the dial counterclockwise to lower the trajectory. (refer to step 10)
Jammed	Bad BBs, oversize BBs	0.2 g to 0.25 g 6 mm caliber BBs are recommended for optimum performance.
	Foreign matters or oil in the inner barrel.	Clean the inner barrel.

## 16 PARTS DIAGRAM

\*The components/accessories for each model may have kind of differences depending on the actual goods. Images are only for reference.

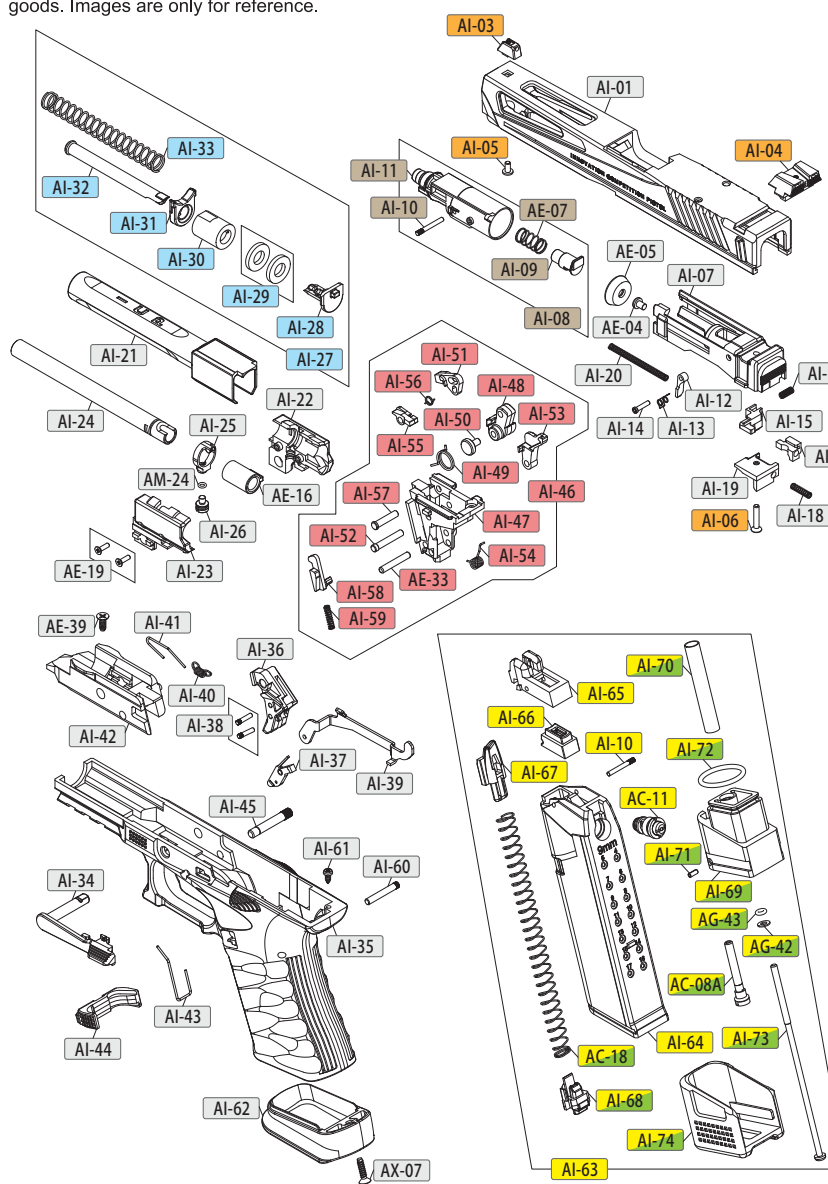

## 17 PARTS DESCRIPTION

ITEM#	DESCRIPTION	Q'TY	ITEM#	DESCRIPTION	Q'TY
AI-01	ICP Slide	1	AI-52	ICP Hammer Pin Ø3*L17.1 (10pcs)	1
AI-02	ICP Combat Sight Combination	1	AI-53	ICP Sear (2pcs)	1
AI-03	ICP Combat Front Sight	1	AI-54	ICP Sear Spring (10pcs)	1
AI-04	ICP Combat Rear Sight	1	AI-55	ICP Auto Sear (2pcs)	1
AI-05	Front Sight Screws M2.5*L5 (10pcs)	1	AI-56	ICP Auto Sear Spring (10pcs)	1
AI-06	Rear Sight Screw M2.5*L14 (10pcs)	1	AI-57	ICP Auto Sear Pin Ø3.1*L14 (10pcs)	1
AI-07	ICP Cylinder Housing	1	AI-58	ICP Hammer Bar Disconnecter (2pcs)	1
AI-08	ICP Cylinder Combination	1	AI-59	ICP Hammer Disconnect Pin Spring (10pcs)	1
AI-09	Cylinder Valve	1	AI-60	ICP Hammer Combination Pin n3*L20.5 (10pcs)	1
AI-10	Magazine Lip Pin n2*L17 (10pcs)	1	AI-61	Button Head Cross Self tapping screw M2.6*6L (10pcs)	1
AI-11	ICP Cylinder	1	AI-62	ICP Magwell	1
AI-12	ICP Push Bar (5pcs)	1	AI-63	ICP Magazine (30Rounds)	1
AI-13	ICP Push Bar Spring (10pcs)	1	AI-64	ICP Magazine Case	1
AI-14	ICP Push Bar Pin (10pcs)	1	AI-65	ICP Magazine Lip (5pcs)	1
AI-15	ICP Full Auto Selector (2pcs)	1	AI-66	ICP Magazine Nozzle Seal (10pcs)	1
AI-16	ICP Full Auto Switcher (2pcs)	1	AI-67	ICP Magazine Follower (2pcs)	1
AI-17	ICP Full Auto Selector Spring (10pcs)	1	AI-68	ICP Magazine Plate Stopper (2pcs)	1
AI-18	ICP Full Auto Switcher (10pcs)	1	AI-69	ICP Magazine Base	1
AI-19	ICP Full Auto Selector Cover (2pcs)	1	AI-70	ICP Gas Line	1
AI-20	ICP Cylinder Housing Spring (10pcs)	1	AI-71	ICP Magazine Plate Stop Pin n2x5 (10pcs)	1
AI-21	ICP Outer barrel	1	AI-72	O-Ring ID18.8xd2.08 (10pcs)	1
AI-22	ICP H-UP Chamber-Right	1	AI-73	ICP Button Head Cross Screw M3*L100 (5pcs)	1
AI-23	ICP H-UP Chamber-Left	1	AI-74	ICP Magazine Plate (2pcs)	1
AI-24	Inner Barrel (103mm)	1	AI-75	Magazine Extension for TM 17 Series GBB pistols	1
AI-25	ICP TDC H-UP Pressure Plate	1	AC-08A	Revo Quantitative Gas Injection Valve	1
AI-26	ICP H-UP Adj. Dial (2pcs)	1	AC-11	Revo.II Efficient Gas Release Valve	1
AI-27	ICP Guide Rod Combination	1	AC-18	CO2 Magazine Spring-Long (2pcs)	1
AI-28	ICP Guide Rod Base	1	AE-04	M1 Screw (20pcs)	1
AI-29	ICP Guide Rod Washer (5pcs)	2	AE-05	XAE Valve Plate	1
AI-30	ICP Recoil Spring Guide (2pcs)	1	AE-07	XAE Valve Spring (10pcs)	1
AI-31	ICP Guide Rod Adapter (2pcs)	1	AE-16	H-UP Bucking	1
AI-32	ICP Guide Rod	1	AE-19	XAE H-UP Chamber Screw (20pcs)	2
AI-33	ICP Recoil Spring (2pcs)	1	AE-33	Slide Catch Lever Plate Pin (20pcs)	1
AI-34	ICP Slide Catch	1	AE-39	Slide Positioning Block Screw (20pcs)	1
AI-35	ICP Frame	1	AG-42	Washer (20pcs)	1
AI-36	ICP Trigger	1	AG-43	Screw O-Ring (20pcs)	1
AI-37	ICP Trigger Safety Lever	1	AM-24	O-Ring (20pcs)	1
AI-38	ICP Trigger Safety Lever Pin Ø2*L9.5 (10pcs)	1	AX-07	Long Frame Adapter Screw (20pcs/pack)	1
AI-39	ICP Trigger Bar	1			
AI-40	ICP Trigger Spring (10pcs)	1			
AI-41	ICP Slide Catch Spring (10pcs)	1			
AI-42	ICP Trigger Housing	1			
AI-43	ICP Magazine Catch Spring (10pcs)	1			
AI-44	ICP Magazine Catch	1			
AI-45	ICP Trigger Combination Pin n4*L26.5 (10pcs)	1			
AI-46	ICP Hammer Combination	1			
AI-47	ICP Hammer Housing	1			
AI-48	ICP Hammer	1			
AI-49	ICP Hammer Spring (10pcs)	1			
AI-49A	ICP Hammer Spring 150% (10pcs)	1			
AI-50	ICP Hammer Guide Wheel (2pcs)	1			
AI-51	ICP Hammer Bar (2pcs)	1			